

SURVEY OF A KING ISLAND KAYAK

**Canterbury Museum
Christchurch, New Zealand
1997**

Peter Sullivan and Paul Caffyn

**Published: August 1998, for the Canterbury Museum, Rolleston Avenue,
Christchurch, New Zealand**

SURVEY OF A KING ISLAND KAYAK

Canterbury Museum, Christchurch, New Zealand

31 October to 1 November 1997

Abstract:

Prior to 1893, a skin kayak was obtained by the US Warsloop *Bear* from 'natives near Behrings Strait', Alaska. This kayak was purchased by the Canterbury Museum (Christchurch, New Zealand) in July 1893 where it remains in storage along with approximately 2000 Inuit items.

In mid 1997, at a meeting of the Canterbury Sea Kayaking Network, the invited speaker, Roger Fyfe, Ethnologist at the Canterbury Museum mentioned that as far as he was aware, no survey had ever been done on the kayak. After the meeting Peter Sullivan offered to carry out a survey.

A background history of King Island and its Inuit inhabitants is presented, with a probable explanation for the collection of the kayak. Details of the kayak survey technique are discussed with an overview of the kayak, its construction, materials used and its accessories.

The team who undertook the task were:

Roger Fyfe: Ethnologist, Canterbury Museum.

Peter Sullivan: Computer Aided Design Tutor (Christchurch Polytechnic), Secretary of Kiwi Association of Sea Kayakers of NZ Inc, (KASK), kayak designer.

John Kirk-Anderson: Professional photographer (Christchurch Press), Sea Kayaking guide and Instructor, KASK member.

Ray Forsyth: retired (Department of Conservation), KASK member.

Don Currie: Air Traffic Controller, kayak and accessory designer, KASK member.

Paul Caffyn: Geologist, author, past President and Life Member KASK.

Brian Wentworth: Joiner, Canterbury Museum.

Chrissie Williams: Proof reader, KASK member.

Collection of the Kayak:

The original Canterbury Museum record catalogue note for this kayak is:

' Purchased: Obtained by the U.S. Warsloop 'Bear', from natives near Behrings¹ Strait. (W.F. Le Warne). 11 July 1893. Re-catalogued EA 1980.13 10.'

Apart from this brief catalogue entry, there is no other information. A quick comparison of this kayak with photographs and line drawings established this was a typical, but perfectly preserved, example of a King Island kayak.^{2, 3} Thus we may assume the kayak was obtained by the U.S. Revenue Marine vessel, 'Bear' from King Island, prior to 1893. It was purchased by the museum on 11 July 1893 from a W.F. Le Warne whose descendants are still resident in Lyttelton. Exactly how and when the kayak was moved to Christchurch remains a mystery.

¹ Old spelling for Bering Strait

² The Bark and Skin Boats of North America – Edwin Tappan Adney and Howard T. Chappelle – p198

³ Contribution to Kayak Studies – Editor – E.Y.Arima, 1991 - "The King Island Kayak" – John D. Heath

King Island Location:

King Island lies in the northern end of the Bering Sea, which extends between the Aleutian Island chain and Bering Strait. The island is 31 miles (51km) off the coast of Alaska and 44 miles (70.4km) south of Cape Prince of Wales, which marks the eastern side of the Bering Strait. The nearest major Alaskan town is Nome, which lies 82 miles (131km) to the east south east, although there are closer, small coastal villages at both Wales and Port Clarence.

The island was first sighted and named by Captain James Cook on 6 July 1778, although he did not land. The 1908 Edition of the 'Alaska and Bering Sea Pilot' has the following description:

King Island, rugged and rocky, composed of basalt, about 2 miles square, and 700 feet above high water; has nearly perpendicular cliffs, deep water, and generally rocky bottom on all sides. On the summit of the cliffs, are a number of columns, resembling the remains of an old castle. There is a native village on the southern side, the houses being built in the sides of the cliffs, some distance above the water. In clear weather the island is an excellent landfall for vessels coming from southwards and bound for Port Clarence.

HISTORICAL BACKGROUND OF KING ISLAND

The King Islanders:

The King Islanders lived in a small village on the south side of the island, known as Ugiuvak but also called Ukiuvok or Ukivok. The earliest description of the villages located is from 'Eskimoland Speaks' by W.B. Van Valin (1945). The author was a teacher who taught at Sinuk from 1911-12 and Wainwright from 1913-15 with US Bureau of Education. In early June 1911, he sailed from Sinuk (26miles WNW of Nome) on a ten ton power schooner with an 11 man Eskimo crew from Sinuk River for King Island via Nome. The objective of the trip was a walrus hunt:

When we reached shelter on the lee side of the island, we were surrounded with a fleet of kyaks. Some of them were built for two persons; the others single holed ones, were lashed in pairs to ensure stability while throwing spears at ducks.

There was no beach for landing, so we shoved our dory across the cake of ice, launched it, and rowed to the big rocks. Leaping from one to the other, we made our way to the shore at the foot of the rocky cliffs, then zigzagged up the trail to Ookevok, the village on stilts. The Eskimo stilt dwelling is built by standing two long poles of driftwood, on end ten or twelve feet apart. Between these, a cross-pole is lashed at right angles about twenty feet above the ground. Other poles are laid on this cross-pole and fastened into the rocks in the rear. This timberwork constitutes the foundation for the floor. The sides and top are then raised and covered with dry grass. The entire igloo is covered and lashed securely with green walrus hides. As these dry, they draw as tight and hard as a fibre trunk. This habitation is absolutely windproof and rainproof.

The kanatenny (storm shed), where hunting outfits, food for current use and all kinds of gear are stowed away, is entered first. From this, the living and sleeping room is entered through a hole about eighteen inches in diameter, by the entrant's getting down on all fours and pushing his head against

the skin that hangs down over the wall on the inside to keep the cold air out. Of all insufferable odours, those of an Eskimo igloo are the most overwhelming. Old seal oil, the chief source of the noisome fumes, is so odoriferous that a polar bear, so it is said, can smell it at a distance of 150 miles when he is travelling against the wind. The air in an igloo soon gets stuffy, thick, and so hot that those inside must peel their fur clothing down to the waistline. My first igloo visits were of necessity very brief, for I would hold my breath from entrance to exit. But one soon overcomes this finicky attitude and becomes indifferent to this as well as to most of the other inconveniences in Alaska.

There was a large double cave at the foot of the island, to the left of the village, which used to serve as a refuge when enemy tribes on the warpath came over from East Cape Siberia, and from the Diomed Islands. The main cave ends about a hundred feet back from its mouth, but there is a secondary cave about ten feet above the regular floor. In ancient times, to gain this second level a piece of driftwood was driven tightly across the mouth, and a rope was thrown over it by which the Eskimos drew themselves up with their food, water, and weapons of defence.

These islanders, marooned here nine months out of the year, make the finest walrus hide rope to be seen anywhere among the Eskimos. It is about the diameter of window sash cord. They are also very clever in making cribbage boards out of walrus tusks, with beautiful pictorial carving. The lines in the ivory are incised with a piece of pointed metal, such as a nail or a knife blade. When finished, the drawing is brought out very clearly by smearing it with soot or ink, or by lead-pencil marks. When enough black has settled in the grooves, the surplus is washed off. Their long winter's work ends in June, when the south current sets in and clears the ice out of Bering Sea. Then they load their oomiaks and sail to Nome pitch their summer camp on the sand spit, and sell their ivory curios to the Nome shops and to tourists.

Approaching the island, I had noticed large rectangular objects scattered over the village. Upon investigation I found that these were walrus hides, laced together in large frames of driftwood to dry. I observed a woman working on one of these skins thrown over a strangely shaped board. Since walrus hides in their original state are too thick for oomiaks (skin boats), the Eskimo has learned to overcome this serious difficulty by making two skins out of one. This is the only place I have seen this accomplished. This woman was just completing the splitting of a ten-by-twelve foot walrus hide with her oolooruk (an Eskimo woman's knife, triangular-shaped, with an ivory handle fastened to one of the points). She gave the knife a rocking motion, holding her free hand against the outside of the skin to feel the thickness as she was splitting it. She made two beautiful skins out of one hide without cutting a hole in either one.

The King Islanders and Walrus:

The main reason for the establishment of the village on King Island appears to be close proximity to the annual migration path of the Bering and Chukchi sea walrus herds. Walrus were vital for the King Islander's survival, providing:

- Meat,
- Blubber which was used for lighting, cooking and home heating,
- Hides for kayaks, umiaks and rope,
- Ivory tusks for harpoon heads, and carvings for trade.

In 1845 however, Yankee whalers entered the Bering Sea, chasing Bowhead and Sperm whales for the lucrative demand for oil and baleen. The whalers subsequently caused a severe decline in walrus numbers that had a dramatic influence on the King Islanders and other Inuit villages on the coast of the Bering and Chukchi Seas.

William R. Hunt in 'Arctic Passage' notes:

When Bering Sea whalers found the Bowhead and sperm whales in short supply, they sometimes hunted walrus for their oil and tusks. Walrus could be harpooned when they were swimming, but more often they were killed with rifles while they congregated on ice floes or on the rocky breeding grounds found on several Bering Sea islands. Russian hunters decimated most of the Pribilof herds when their fur-seal yield of the islands diminished, and American whalers hunted walrus intensively in other places. It has been estimated that a total of 200,000 were killed from 1860 to 1880.

Unlike the Inuit, the white men took only the oil and ivory, wasting the flesh and hides. Fortunately for the preservation of the walrus and for the Inuit who subsisted on these animals, the decline of the Bering Sea whale fishery occurred before they were entirely wiped out. The walrus hunt was devastating and wasteful. Hunters were not concerned for the people who depended on the hides and meat. After the slaughter, hunters stripped the blubber from their catch and left the rest, save the tusks, on the ice. The blubber was carried to a ship and tried or boiled down in the same manner as whale blubber. A kill of 500 walrus would yield about 300 barrels of oil.

Fortunately for the Inuit, the whaling ships that headed north through Bering Strait in 1871, did so for the last time. The entire fleet was caught in the ice near Point Barrow, and all the ships were lost. The whaling industry never recovered from this disaster and it may have saved the walrus and northern Inuit from extinction.

This near extinction of the walrus herds and effect on the King Islanders is graphically described in the following account from, 'GALES, ICE AND MEN', a biography of the Steam Barkentine 'Bear' by Frank Wead. The 'Bear' in 1890 was under the command of Captain M.A.Healy, and on her annual Alaskan patrol for the U.S. Revenue Marine Department.

Later that year, soon after the ice opened, the 'Bear' reached King Island. While still some distance from the landing place, her men saw that it was crowded with strangely quiet Eskimos. Kayaks and oomiaks were putting out from the shore. As the Eskimos clambered over her rail their bony hands and pinched faces graphically portrayed their hunger. They touched the men of the Bear with gentle fingers, as if anxious to make sure they were really there, thanked them for coming and then bolted for the galley, piteously begging food.

In painful, heart-broken words, the chief informed Captain Healy that two hundred of his people had died of starvation during the winter; only one hundred men and women were still alive on King Island. The walrus, depended upon to provide them with food, had failed to appear during the preceding fall. Winter storms made passage to the mainland impossible. The survivors had first eaten their dogs and then subsisted for months upon seaweed. Before the 'Bear' steamed on for Barrow with the whalers, food supplies from her storerooms were ferried ashore, platforms were built,

in accordance with Eskimo custom, for the burial of the dead, the community was nursed back to health.

This description of the 1890 visit by the 'Bear' is included as it predates the 1893 Canterbury Museum King Island kayak purchase by only three years. The tragic deaths of 200 King Islanders would have led to numerous kayaks without paddlers, hence it is logical to assume that the Canterbury Museum kayak was probably collected during this visit, and exchanged or bartered for food or ivory.

Later Years of King Island:

In 'Sea of the Bear', M.A.Ransom describes a visit by the 'Bear' to King Island in 1921. A photograph of the 'pole' house villages shows corrugated iron cladding for the house and roofs. Ransom noted that about 4 July each year, all the villagers, dogs and household gear, loaded aboard the umiaks and choosing a good day, would make a dash for the mainland and then hug the coast to Nome where they spent the summer. The 'Bear' often helped out with the return trip in late summer when the islanders were loaded up with food and goods for the long winter.

In 1966, the King Islanders abandoned the island and moved to the outskirts of Nome, in order to send their children to school.

THE SURVEY

Initial Survey Requirements:

The initial measurements were taken over a weekend in October 1997. Several trips to the museum were made prior to this to ensure that adequate space, lighting and cradling for the

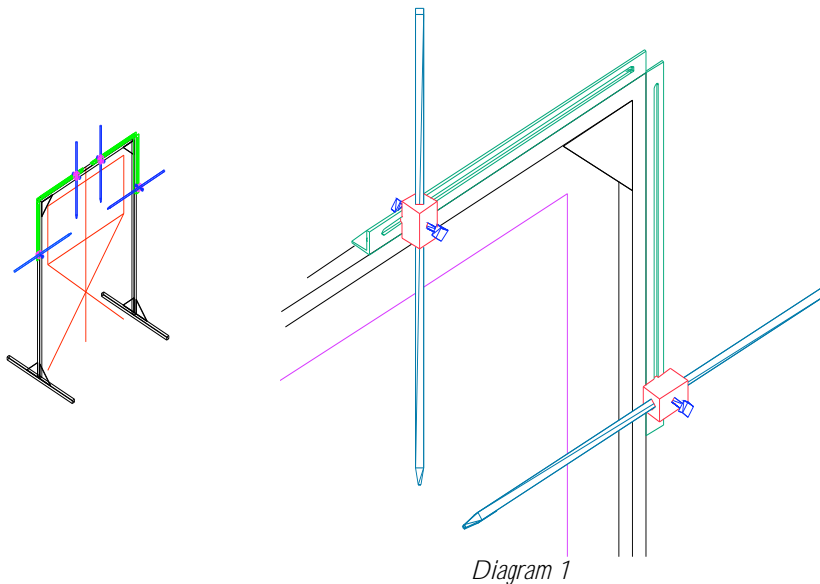

kayak was available. A measuring jig (*diagram 1*) was designed and constructed (by Peter Sullivan) so as to take X (horizontal) and Y (vertical) coordinates from the hull and deck.

The Method:

The jig straddled the kayak, (*figure 1*) which was positioned on cradles constructed by Brian Wentworth. After the kayak was made level, plumb lines were dropped to the floor from each end and parallel lines were stretched along the floor as a carriage way for the measuring jig. 100mm marks were scribed at right angles to these lines square to the centre line of the craft. X and Y coordinates were taken and noted from each of the longitudinal stringers at 100 mm increments by positioning the jig at each of these 100mm increment marks.



Figure 1.

All measurements were taken from the bow to the stern with Peter and Don taking the coordinate readings from each side and Ray acting as scribe. (Paul Caffyn is shown taking measurements in figure 1.)

Two sets of drawings have been created – one set which are included in this survey and another which is fully dimensioned to allow for the construction of replicas (synthetic fabric covered; the use of seal and walrus hides is illegal in New Zealand.)

John Kirk-Anderson took numerous photos of the craft, particularly of the inside. As the kayak is fully skinned, construction methods of the bow and stern framework could not be recorded.

The drawings were completed in AutoCAD LT3 and the jig drawings in AutoCAD R14. Don Currie did some traditional drafting of the bow and stern using calipers. He also used a strong light and backdrop to produce silhouettes of the bow and stern sections as a backup for checking the CAD drawings.

The X, Y and Z (longitudinal) coordinates as taken from the measurements were fed into CAD as points, which were then joined by lines both horizontally and vertically.

The bow and stern sections drafted on paper were initially covered in a 10mm (1cm) grid. The coordinates taken from this grid were fed into the CAD drawings. Comparisons of the various hand prepared drawings proved a good match to the CAD drawings.

Ray Forsyth spent considerable time taking notes, rubbings and sketches of various features, particularly the thwart profiles and cockpit area. The cockpit rubbing was also overlaid with a grid, and the resulting coordinates placed into the drawing.

After the initial coordinates were completed in CAD and the raw data looked a bit like a kayak, the task of 'straightening' the craft took place. By taking coordinates at each 100mm in the Z-axis, enough information was gathered to compare both sides of the hull and deck. This indicated whether a prominent feature like a bulge, hump or hollow was intentional or otherwise. Any possible problem areas, which did not feature on the mirror images, were deleted and the craft profile adjusted accordingly.



Figure 2.

In plan form the centre section is almost parallel with the bow and stern, sections at the water line being nearly symmetrical. The craft has a prominent twist (approx. 60mm (16.5degrees)) as well as bulges in both the fore and aft sections on either side of the hull (at opposite ends). (*figure 2.*)



Figure 3.

A large cockpit opening, transverse hide thongs immediately in front and rear of the cockpit, a small bone paddle rest (*figure 6.*) attached by a thong to the fore-deck, make up the deck layout. A thong attached through the bow hole (*for knot detail see figure 14.*) extends back to

the fore-deck transverse thong and a small loop (hand loop?) is attached to the rear deck, just prior to the deck sloping back to the stern. (*figures 3 & 4*)



Figure 4.

The hull has a definite sway back (hog shear) of the keel, which is quite uniform. It is assumed that it was deliberately included when constructed⁴ and wasn't removed from the drawings. (*figure 4.*)



Figure 5.



Figure 6.

The hull frames were not laid out at right angles to the gunwale but tended to 'slope towards the stern'. (*figure 5.*)

A small highly polished, carved bone (paddle/harpoon rest?) is slung from a leather thong attached to the cockpit side of the triangular hide insert on the fore-deck. (*figure 6.*)

AN OVERVIEW OF THE KAYAK

Construction Materials:

It is not possible to take pieces of the skin or frame for analysis. Visual examination indicated that the skin covering (in three pieces; - two covering the hull and deck and a heart shaped section included in the fore-deck) was made of walrus and/or seal skin.⁵ (*figure 7*)

The frames (ribs) were of wood 'in the round' i.e. in their natural growing condition, retaining their bark, but compressed and bent as shown in figures 9 - 13. Material for these

⁴ Contributions to Kayak Studies – Arima E.Y. Editor – The King Island Kayak – John D. Heath – p14.

⁵ The King Island Kayak – John D. Heath

may have been obtained locally from species of willow (family *Silicaceae*) recorded as growing in the area.⁶

The remainder of the frame appears to be worked (cut, carved and/or shaped) timber. Some pieces, up to approximately 4400mm (14ft 6inches) were used for the keel and gunwales. Sources for these longer pieces of timber could be as driftwood, dunnage from ships or timbers from wrecked European ships.

From what can be seen in and on the kayak, no metal has been used in its construction. All joints that can be viewed are secured with wood tenons or hide lacing.

The Kayak and Accessories:

The hull and deck covering is seamed circumferentially at approximately one third of the kayak length from the bow end. Three pieces of hide (including a triangular section sewn in the deck immediately in front of the cockpit) form the kayak covering. Thongs which cross the fore-deck pass through the skin covering and are lashed to the second thwart forward of the coaming. (*figure 9*)



Figure 7.

An almost heart shaped piece of hide (*figure 7*) has been included in the fore-deck covering. Possible reasons for this are:

- a: as reinforcing for the main 'work' area immediately in front of the paddler/hunter
- or
- b: as a 'fill in' piece to increase the width of the hide so that the joining seam follows a single line around the circumference of the craft.

⁶ Viereck Leslie A. and Little (Jr.) Elbert L. 'Alaska Trees and Shrubs', Forest Service, U.S. Department of Agriculture, Agriculture Handbook Number 410. 1972



Figure 8.

The hull has several patches, which from the neatness and regularity appear to have been implemented prior to the fitting of the skin. (*figure 8.*)

Another small patch has an insert on the inside suggesting that it was a later addition?

Several ribs and thwarts have been broken or damaged (distorted) without the hide covering being damaged in any way in the vicinity. Perhaps during transport to NZ when the skin was still flexible, the craft may have been crushed, damaging the frames with the hide being resilient enough to withstand the pressure.

Another possibility is that the damage occurred during the severe climatic changes encountered in transporting the kayak from the Arctic to New Zealand as the skin dried and tightened. The stern section skin cover over the keel has been worn away, with the wooden keel visible for approximately 70mm.



Figure 9.

The thwarts in the mid-section are one piece whilst those further forward and aft are constructed from three pieces. (*figure 9*) The steepness of the deck may have necessitated the

use of multi pieced thwarts as wide timber may have been scarce. Using shorter pieces to construct the thwarts may have been stronger as the direction of grain in the timber could be controlled.

Construction methods apart from in the mid-sections are difficult to view so were not determined. Assuming those that can be viewed are typical, the remainder are described comprehensively in a paper by John D. Heath – 'The King Island Kayak' – 1971, in 'Contributions to Kayak Studies' edited by E.Y.Arima (1991)



Figure 10.

Many of the frames and stringers have small flat pieces of packing (wood, bone, hide?) inserted to eliminate hollows in the initial layout of the hull prior to the fitting of the skin. Figure 10 clearly shows the one piece thwart profile immediately in front of and supporting the coaming. Slits can also be seen in the hide enabling it to be wrapped evenly around the coaming timber.

The skin, which has been stretched to form the cockpit rim, is stitched and tensioned with a hide thong which is sewn approximately half way through each piece i.e.: the thong doesn't pass right through the hide. The hide varies from 2-3mm thick in this area.

The mortise holes in the gunwales vary from rectangular to oval in no discernible pattern. One damaged frame has been lashed. The blocks of timber, which support the cockpit rim at the sides, are lashed back to the first longitudinal stringer. (*figure 11*)



Figure 11.

The single thong, which attaches the frames to the stringers, is shown in the figures 12 and 13. This lashing method might indicate that the hull was quite flexible, with any rigidity and stiffness being imparted by the skin covering. Compression marks clearly show the method used to bend the frames (compressing the fibres with either teeth, hammer or stone?)



Figure 12.



Figure 13.



Figure 14.

The bow has a small patch on the extreme front with lashings through the hand hole ⁷ running back to the fore-deck. (*figure 14*) From John Heath's paper, the bow hole was used as a hand-hold when transporting the kayak attached to a sled across ice floes. The elliptical hole 61mm x 43mm holds three of my fingers rather uncomfortably so it is assumed that either the original owner had extremely small hands and towed the kayak for short distances (the stitching would have cut into palm or fingers). Maybe a loop of hide was attached through the hole (a bit like modern hand holds on kayaks)? This could be assumed as a possibility as the stern is fitted with a loop.



Figure 15.

Three small wooden plugs are tied to frames inside the cockpit. (*figure 15*) One viewpoint overhead was that these plugs were inserted into the wound hole of the seal or walrus and

⁷ The King Island Kayak – John D. Heath – p7

turned through 90 degrees and used as towing anchors. If the hole in the plug was central this may be a possibility, but the plugs shown have their holes close to one end making this theory fairly improbable, as the plug would pull out of any hole fairly quickly. Another theory aired was that the plug placed into the wound hole caused by a harpoon might stop the animal from sinking?



Figure 16.



Figure 17.

Figure 16 shows a coarsely sewn patch, which reinforces the area on the fore-deck (at the main seam between the fore and rear skins) where the transverse thongs pass through the hide and are knotted at the central seam. At the gunwales the thong passes through the skin, through drilled holes in the gunwales and is pulled back and fixed around a frame. (*figure 9*) Figure 17 shows a similar arrangement for the deck line on the rear deck immediately behind the cockpit. Note the small tear, which has been repaired, in the lower left of the picture. A blade may have caused this tear when the (walrus?) hide (used as covering for the stern section) was split in two to decrease the thickness prior to fitting it on the kayak.⁸

⁸ The King Island Kayak - John D. Heath – p 8



Figure 18.

Included with the kayak is a piece of rather hard, dark brown hide (*figure 18*) approximately 1000mm x 600 mm x 5mm thick. Possible uses are:

- a:* as a seat (the craft hull shape would indicate that it may be rather unstable so a low centre of gravity i.e. sitting on the bottom may be prudent.)
- b:* as protection for the inner stringers and frames when the paddler was entering or exiting the kayak
- c:* as protection for the craft when loading the kayak with cargo (slain seals?)
- d:* or maybe it has no association with the kayak and was included only as packing or protection for the voyage to NZ.

A double-ended non-feathered paddle is also shown in figure 18. It has vestiges of black colouring on the blade tip and red colouring on the remainder of the paddle. The paddle shaft is oval with a fine groove extending the length of the shaft. Whilst this paddle and another single ended paddle are included in the museum's collection it is not conclusive that they came with the kayak from the King Island area. (John Heath mentions that the preferred paddle is single ended but double-ended paddles were used for extra speed.)

REFERENCES:

Adney, Edwin T. and Chappelle, Howard I.,
1983: 'The Bark and Skin Boats of North America',
Smithsonian Institution Press, USA. – ISBN: 0-87474-204-8

Page 198 contains a kayak survey drawing of a King Island kayak that was collected in 1888 by Capt. M.A. Healy, U.S. Revenue Cutter, 'Bear'. It is referenced as USNM 160326, in the U.S. National Museum. Page 199 contains a single paragraph description of the King Island kayak.

Arima, E.Y.; - editor
1991: 'Contributions to Kayak Studies',
Canadian Museum of Civilization, Mercury Series, Paper 122.
ISBN: - 0-660-12913-2

This contains the most important work on King Island kayaks to date; a paper by John D. Heath titled, 'The King Island Kayak', which was written in 1971. It includes a full description of kayak construction, framework assembly, covering the kayak, equipment and its use, and four detailed survey drawings of three single and one double kayak. Twelve photographs are included plus four figures detailing construction techniques and seam stitching details.

Hunt, William R.
1975: 'Arctic Passage' – ISBN: - 0-684-14466-2

Ranson, M.A.
1964: 'Sea of the Bear' – (No ISBN)

Hydrographic Office, U.S.Navy
1908 edition
'Alaskan and Bering Sea Pilot' – (No ISBN)

Van Valin, W.B.
1945: 'Eskimoland Speaks' – (No ISBN)

Viereck Leslie A. and Little (Jr.) Elbert L.,
1972: 'Alaska Trees and Shrubs'. Forest Service, U.S. Department of Agriculture,
Agriculture Handbook Number 410

Wead, Frank
1937: 'Gales, Ice and Men' – A biography of the steam barkentine 'Bear'
(No ISBN)

Zimmerly, David
1986: 'Qajak - Kayaks of Siberia and Alaska',
Alaska State Museum, USA. – (No ISBN)

Pages 53 - 62 describe the Bering Strait type kayaks, with six pages specific to King Island kayaks. Numerous photographs include rolling technique, and a King Island kayak frame. Pages 74 and 75 include descriptions, and line drawings of single and double bladed paddles used.

GLOSSARY:

- Keel/keelson:** The backbone of the kayak. The trapezoidal longitudinal centre hull stringer equidistant from both gunwales following the centre line of the kayak.
- Thwarts:** Deck frames at right angles to the keel, which support the deck and hold the gunwales apart.
- Gunwale:** Two longitudinal stringers, which separate the deck from the hull, usually at the widest point. The hull frames and the deck thwarts are mortised into the gunwale.
- Frames:** Also referred to as 'Ribs'. Most commonly half round shaped curved lengths of timber which when spaced approximately 100mm apart and mortised into the underside of the gunwale form the transverse shape of the hull. The frames support the stringers.
- Stringers:** Longitudinal members of similar cross section to the frames. The four stringers (on either side of the keel) are lashed to the frames to form the longitudinal shape of the hull. The stringers, gunwales, keel, deck ridge and stern and bow blocks supported the hide covering the kayak.
- Deck Ridge:** The longitudinal deck stringer, which follows the centre line of the kayak. The deck ridge is the equivalent member on the deck, to the keel on the hull.
- Mortise Holes & tenons:** Holes bored into the gunwale into which the frames or thwarts are fitted. The mortise holes in the kayak presented in this paper vary from rectangular to oval. Tenons are the shaped ends of the frames and thwarts, which fit into the mortise holes.
- Hull & Deck:** The hull is the underside of the kayak separated from the deck (the upper section which includes the cockpit) by the gunwales. Sometimes a hull may be generalised as being the complete kayak.
- Cockpit:** The opening through the kayak deck, through and in which the paddler sits or kneels.
- Coaming:** The outer and uppermost rim of the cockpit, around which the skin from the deck is attached. *When the breakers were too rough for launching, a man would get into his kayak on the rocks, fasten his walrus gut jacket, imaniitik, around the cockpit rim, then be picked up in his kayak by three or four men and thrown into the sea.*⁹
- Bow:** The front (fore) end of a kayak.
- Stem:** The rear (aft) end of a kayak.
- Thong/s:** Hide (Bearded seal – Ugruk)¹⁰ cut into strips used as rope for deck lines (painters).
- Rocker/Sway Back/Hog Sheer:** The 'curve' in the longitudinal section of the hull. The rocker, either positive or negative is set into the keel to give a kayak varying degrees of manoeuvrability, straight-line speed and other handling characteristics. Negative rocker, (Sway back or Hog sheer) are used in a flexible hull to allow for a load when applied in the centre section of the hull (the paddler etc) to bend and create positive rocker. Negative rocker is when the bow and stern sections of the keel are sitting on a level surface and light can be seen through the area between them. Positive rocker is when the bow and stern sections of the keel are raised and the keel is sitting on the centre section below the cockpit.

⁹ The King Island Kayak - John D. Heath - p 26 - Special Techniques - 1st sentence.

¹⁰ The King Island Kayak - John D. Heath - p 8 - 4th paragraph.

KING ISLAND KAYAK

CANTERBURY MUSEUM
CHRISTCHURCH
NEW ZEALAND

LOA Length overall - 4486mm (14,7141 feet)
Max beam - 612mm (2,0074 feet)
Stern to rear outside cockpit - 1617mm
Stern to front outside cockpit - 2334mm
Kayak dry weight - 16.75kg (26.85lbs)

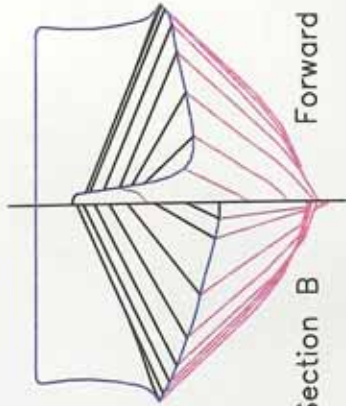

Rear Section B Forward Section A

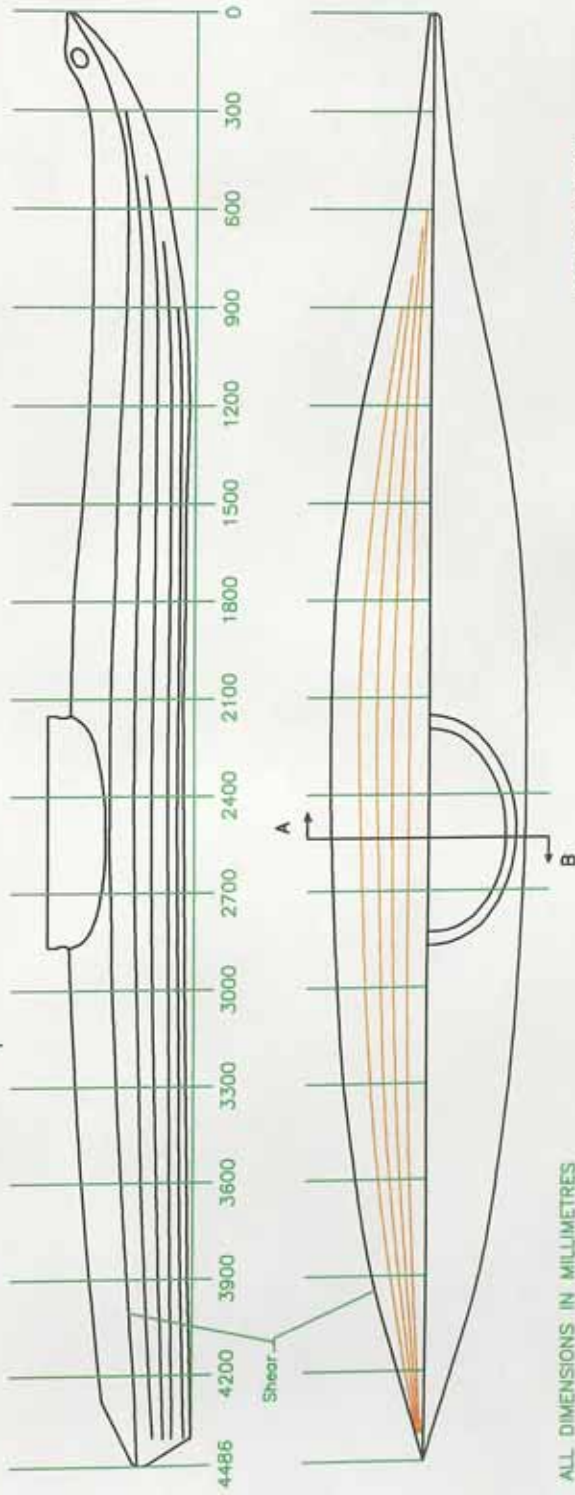

ALL DIMENSIONS IN MILLIMETRES

Peter Sullivan 1988

THE KING ISLAND KAYAK

AT
CANTERBURY MUSEUM
CHRISTCHURCH
NEW ZEALAND

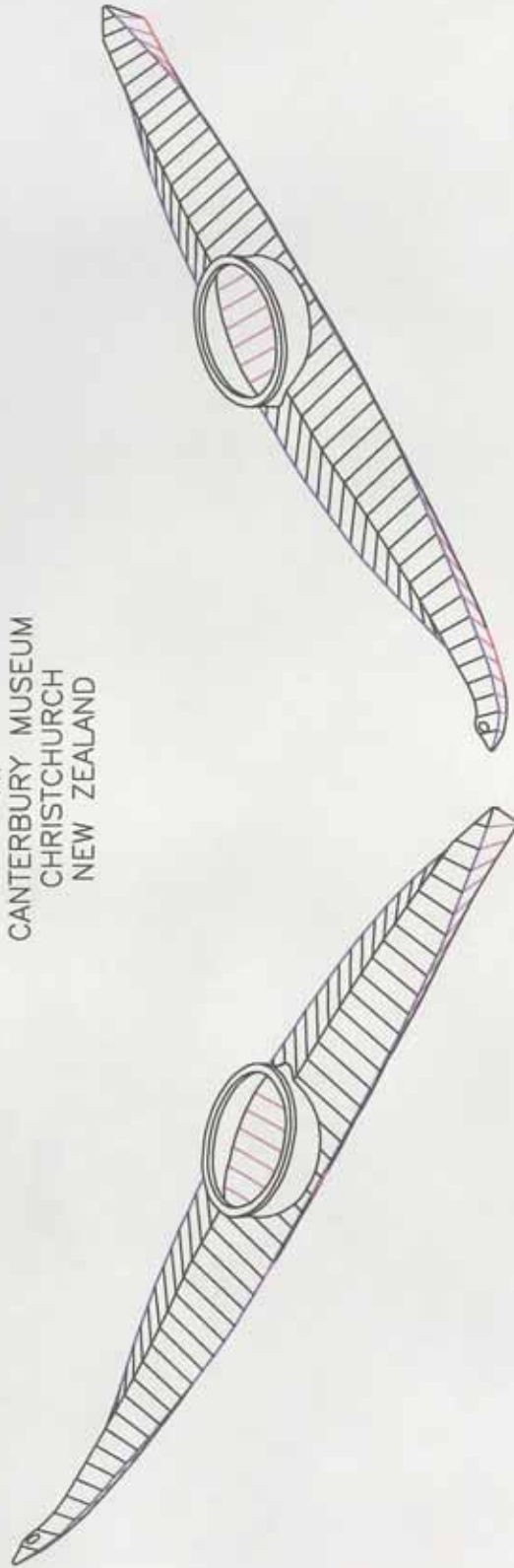

Peter Sullivan 1995